

AUTO TOOLS

A-1

CAR OPENERS

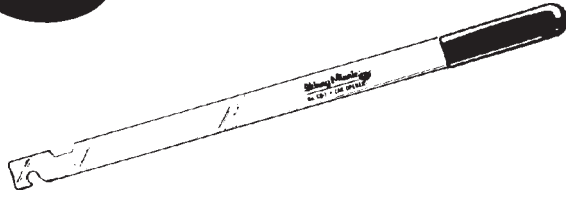

A1-CO1 Skinny Minnie

Still the most reliable and universal car opening tool available. While many newer cars require a more specific device, the Skinny Minnie is still the tool of choice for thousands of cars on the road today.

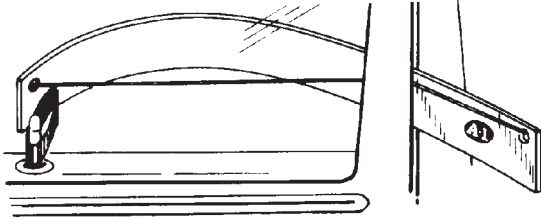

A1-CO2 Vulcan Button Grabber

Unique rubber loop GRABS and HOLDS buttons, without damage. Open up a whole new world with this simple but effective car opener. The rubber loop grabs and holds most buttons, even straight ones. Easily enters through door jam. Use string for alignment. Great for Mercedes, BMW, Volvo.

AUTO TOOLS



CAR OPENERS

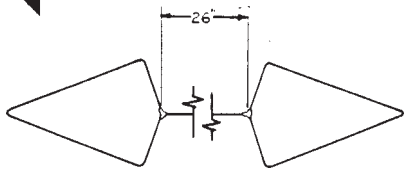

ES-AWT-100 Scrawny Lonnie

The famous tools that professionals use to open locked autos. The wire "snake" reaches in between door frame and glass to the button. No damage to window or weather stripping. Takes a little practice, but once you've got the technique, you'll never miss! (Even works on tapered "No-head" buttons!)



ES-SNIK-1 Slide-Nik

A new unique tool for the professional locksmith! The new SLIDE-NIK allows you to open late model GM doors with slide locks in a matter of seconds. What's more, with a minimum of practice, 1981 and '82 GM doors can also be opened! Comes complete with easy-to-follow instructions.

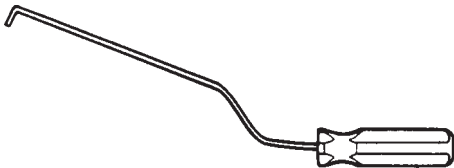

ES-TNIK-3 Trans-Nik

The new TRANS-NIK allows you to open doors on the 1983 and later model CAMARO, Z-28, BERLINETTA, FIREBIRD, AND TRANS-AM. All that is required is a minimum of practice and you will be saving that precious time that means extra profit! The new TRANS-NIK comes complete with easy-to-follow instructions.



ES-CPT-99 Chrysler Door Opener

The ES-CPT-99 Chrysler Door Opener allows you to open most Chrysler doors in a matter of seconds. All that is required is a minimum of practice and you will be saving that precious time that means extra profit! The new ES-CPT-99 comes complete with easy-to-follow instructions.

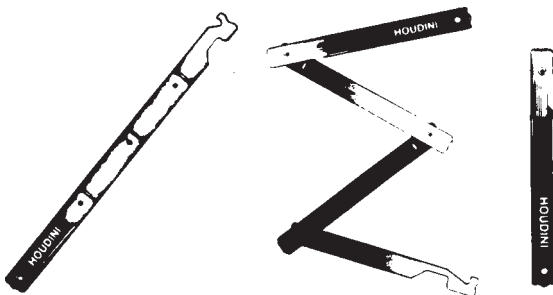

ES-HDNI-1 Houdini™

The HOUDINI™ folds up to fit snugly in your workshirt pocket or neatly in your toolbox. You'll find that the HOUDINI™ eliminates the frustrating problem of misplacing or losing your emergency car door opener!



ES-ASTRO-1 Chevrolet - Astro Van Opening Tool

The ES-ASTRO-1 opens the Astro Van in no time at all with a minimum of effort. The time saved translates into profit in your pocket! The ES-ASTRO-1 is furnished with complete easy-to-follow instructions.

ES-FAV-1 Ford Aerostar Van Opening Tool

The new Ford Aerostar Van Opening Tool is one tool that no locksmith should be without. The ES-FAV-1 quickly and easily opens the Aerostar Van with a minimum of practice, saving you time and putting extra profits into your pocket! Comes complete with easy-to-follow instructions.

AUTO TOOLS



CAR OPENERS

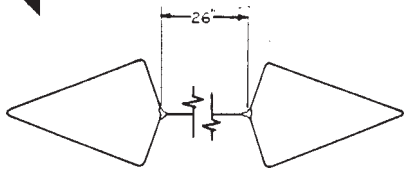

ES-AWT-100 Scrawny Lonnie

The famous tools that professionals use to open locked autos. The wire "snake" reaches in between door frame and glass to the button. No damage to window or weather stripping. Takes a little practice, but once you've got the technique, you'll never miss! (Even works on tapered "No-head" buttons!)



ES-SNIK-1 Slide-Nik

A new unique tool for the professional locksmith! The new SLIDE-NIK allows you to open late model GM doors with slide locks in a matter of seconds. What's more, with a minimum of practice, 1981 and '82 GM doors can also be opened! Comes complete with easy-to-follow instructions.

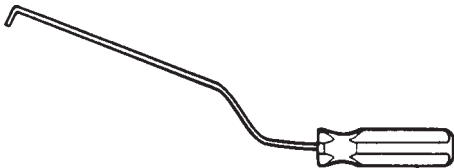

ES-TNIK-3 Trans-Nik

The new TRANS-NIK allows you to open doors on the 1983 and later model CAMARO, Z-28, BERLINETTA, FIREBIRD, AND TRANS-AM. All that is required is a minimum of practice and you will be saving that precious time that means extra profit! The new TRANS-NIK comes complete with easy-to-follow instructions.



ES-CPT-99 Chrysler Door Opener

The ES-CPT-99 Chrysler Door Opener allows you to open most Chrysler doors in a matter of seconds. All that is required is a minimum of practice and you will be saving that precious time that means extra profit! The new ES-CPT-99 comes complete with easy-to-follow instructions.

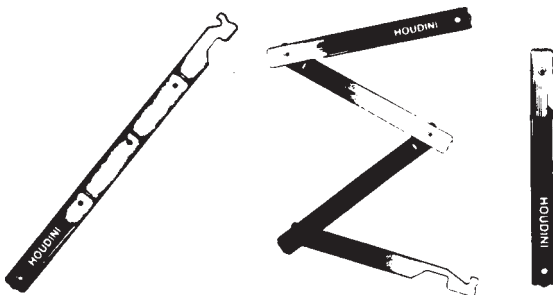

ES-HDNI-1 Houdini™

The HOUDINI™ folds up to fit snugly in your workshirt pocket or neatly in your toolbox. You'll find that the HOUDINI™ eliminates the frustrating problem of misplacing or losing your emergency car door opener!



ES-ASTRO-1 Chevrolet - Astro Van Opening Tool

The ES-ASTRO-1 opens the Astro Van in no time at all with a minimum of effort. The time saved translates into profit in your pocket! The ES-ASTRO-1 is furnished with complete easy-to-follow instructions.

ES-FAV-1 Ford Aerostar Van Opening Tool

The new Ford Aerostar Van Opening Tool is one tool that no locksmith should be without. The ES-FAV-1 quickly and easily opens the Aerostar Van with a minimum of practice, saving you time and putting extra profits into your pocket! Comes complete with easy-to-follow instructions.

AUTO TOOLS

HPC

CAR OPENERS

DELUXE OPENER SET

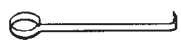

CO-4

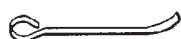

*The only opener
for cars with
vented windows*

This 6 piece tool set is one of HPC's longest standing products. Although it remains virtually unchanged from its original design, the CO-4 has many applications on all models of autos and trucks with vent windows.

COLLAPSIBLE OPENER



CO-6

This tool is the only one (aside from the CO-4) that is currently in production that preceded the Slim Jim™. The CO-6 was retained in HPC's line because it has many current applications. Once the three segments are assembled, the tool totals 62" in length and can reach across the car to unlock the opposite door.

SLIM JIM™



The Original

CO-10

HPC's Slim Jim™ has been the entry tool by which all others have been judged since its introduction back in 1967. Although automobiles have changed considerably in recent years, the large number of applicable cars on the road allows the Slim Jim™ to remain a necessity for all auto lock specialist.

SUPER JIM™



CO-11

The Super Jim™ is a wider version of the Slim Jim™ and on some models may be faster.

SIR JAMES™



CO-18

The Sir James™ is a deluxe version of the Super Jim™. It has pre-scribed depth graduations on its face and has a built-in note pad for recording pick up points and exact opening procedures. Also included is a genuine leather handle.

PEG LEG JIM™



CO-20

The Peg Leg Jim™ is for models worth protected linkage. Some 1980's GM used cylinder covers, etc., on random model autos.

MERCEDES BENZ OPENER



CO-21

This tool open European car models with vacuum operated locks. Since these cars don't die easily, the CO-21 remains an essential tool today. Also, the handle is very useful for many linkage applications.

JIM DANDY™

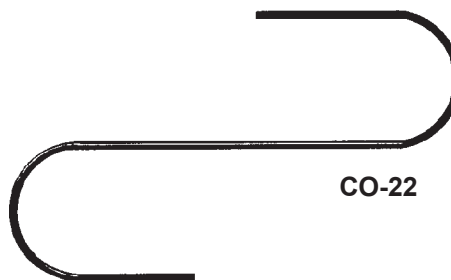

CO-22

The Jim Dandy™ is an extremely versatile under button opener. It is designed for GM models other than "X" and is also great on most Japanese cars and trucks.

AUTO TOOLS

HPC

CAR OPENERS

BIG JIM™



CO-24

The Big Jim™ is made especially for "X" type GM's, plus it will open almost every vehicle that the Slim Jim™ will.

JIMMY™



CO-26

The Jimmy™ opens most grip handle GM models (1970 to 1980) including the Chevrolet Corvette.

VERTICLE LINKAGE MASTER



CO-35

The Verticle Linkage Master was originally intended for use on Ford vans and small trucks, yet has proven to be highly effective on such vehicles as Toyota Cressida, Saab, Nissan Sentra and Maxima, Chevrolet Nova, Chrysler New Yorker and many other vehicles possessing vertical linkage.

CHRYSLER TOOL



CO-37

The Chrysler Tool is an "instant entry tool" specializing in late models. Entry is through drainhole.

VW VENT TOOL



CO-38

This vent tool is designed for many models of Volkswagens. Plus, it can open many domestic vans and pick-ups.

HORIZONTAL HOOK



CO-39

The Horizontal Hook offers a sure way to bind a horizontal rod and open dozens of late model General Motors vehicles.

MERCEDES SEL & SEC OPENER



CO-40

The CO-40 is designed for the infamous SEL and SEC model Mercedes. It is a modified version of the CO-21.

SINDWINDER™



CO-41

The Sidwinder™ opens Ford and Chrysler through the cylinder hole. It works through the drainhole in front of the lock to activate the lazy pawl.

AUTO TOOLS

HPC

CAR OPENERS

FORD THROUGH TOOL



CO-51

Although the Ford through tool was designed for the Ford Thunderbird, Mercury Cougar and Lincoln Mark VII, other autos with vertical button rods and grip handles can also be opened with it.

J FLEX™



CO-57

J Flex™ is a "Jack of all trades". By bending its strong flexible material you can make almost any configuration. Very useful for under button openings in tight spaces.

SUPER J™



CO-52

The Super J™ will allow you to open almost any auto with vertical linkage. The Super J™ was designed to give your Super Jim™ (CO-11) or Slim Jim™ (CO-10), an entirely new application. Either tool will enable the Super J™ to enter the door as a straight tool. Upon removal of CO-10 or CO-11, Super J™ returns to its original form. The bend also allows it to reach locations inside the door that would be otherwise isolated.

POCKET JIM™



CO-58

The modular design of the Pocket Jim™ gives you the flexibility to use any combination of segments to create a variety of tools. The Pocket Jim™ includes tips from the Slim Jim™ and the Peg Leg™. Not only can each tool grasp the vertical linkage straight down for fast opening, but their tips can be rotated a full 360 degrees to locate offset horizontal linkage.

ULTRA JIM™



CO-55

The Ultra Jim™ has the most popular of all car opener designs (Slim Jim™ style) in a flexible material. It allows you to custom bend and fully rotate the tool inside the door to bind or manipulate those hard to reach linkage areas.

CHEVY BERETTA



CO-59

The 1988 Chevrolet Beretta featured a revolutionary automotive locking system. This system proved to be extremely resistant to the car opening tools available at that time. The CO-59 was specifically developed to unlock the Beretta within a span of 30 seconds.

FLEXIBLE PEG LEG



CO-56

All the versatility of Peg Leg Jim™ combined with the flexibility to custom bend and rotate makes this an extremely useful tool for any bell crank, lazy pawl, vacuum boot or latch type opening.

AUTO TOOLS



CAR OPENERS

CADDY KILLER™



CO-60

The Caddy Killer™ is similar to the CO-59, but has increased height in the arc. It can open '86-'94 Cadillac Eldorado, '84-'94 Dodge Ram and '87-'94 Acura Legend and many others.

STRETCH KILLER™

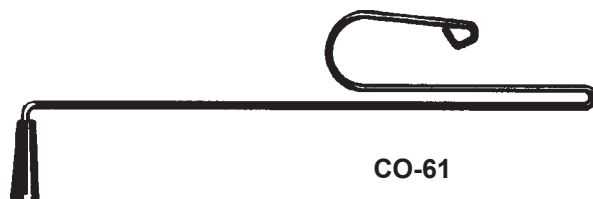

CO-61

The Stretch Killer™ is capable of opening the 1988 through the 1994 Buick Regal, Pontiac Grand Prix, Chevy Astro, etc.

SAFARI JOE™



CO-62

The Safari Joe™ is an extremely useful double sided tool designed to open the following models of GM small trucks: Chevy S10 pick-up, GMC S15 Jimmy (1982-1987), Chevy Astro, GMC Safari (1985-1990), Chevy Nova and Toyota Corolla. It has a slip resistant coating to help bind and move linkages.

GM JOE™



CO-64

The GM Joe™ is an extremely versatile tool which is designed to open almost every car designed by General Motors, in seconds. This includes the following models: Buick, Cadillac, Chevrolet, Oldsmobile, and Pontiac. Even after all the linkage has been disconnected, GM Joe™ can do the job. It goes straight to the latch mechanism (which varies only slightly between different General Motors models).

SUPER JOE™



CO-65

The Super Joe™ is designed to open a wide variety of vehicles having vertical button rods. Chrysler products offer the best applications, though countless other vehicles (especially Japanese imports) can be opened with Super Joe™.

ASTRO TOOL

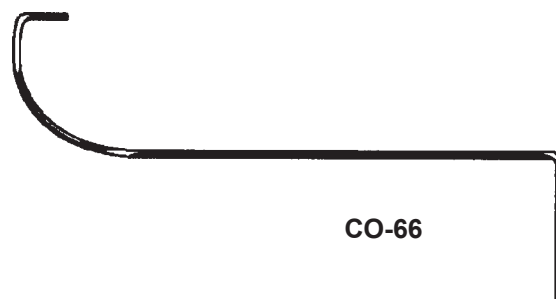

CO-66

The Astro Tool opens all 1984-1994 Chevy Astro Vans, plus most horizontal linkage GM vehicles. The CO-66 has proven to be the quickest, easiest way to manipulate the linkage in the Chevy Astro.

REVERSE OVER HOOK™

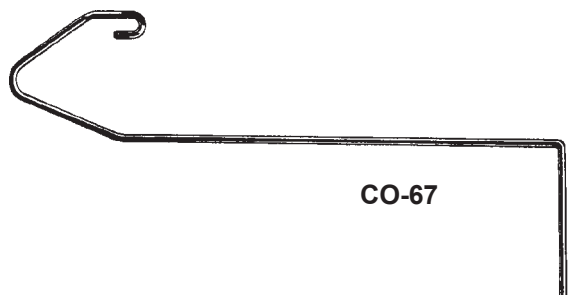

CO-67

The Reverse Over Hook™ is an extremely versatile tool designed to go around shielding and underneath the inner door panel to reach the horizontal linkage. It can also be very effective on vertical linkages. It can lift, lower, and rotate lazy pawls and some bell cranks. This tool is designed to open all General Motors, Ford Mercury, Nissan, Chrysler/Plymouth, Honda, Mitsubishi, Jeep and many more.

AUTO TOOLS

HPC

CAR OPENERS

OVER HOOK™

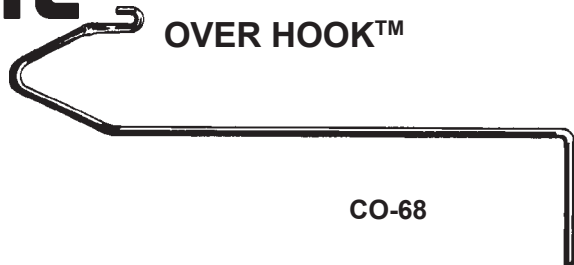

CO-68

The Over Hook™ is designed to hook onto horizontal control rods inside the car door, including some that might be located behind the window or other obstruction. The tool can go down, then back up, behind the window to hook onto a control rod. Although the Over Hook™ is primarily for use on GM cars, it can be used on other vehicles, including several foreign vehicles.

SUPER KILLER™

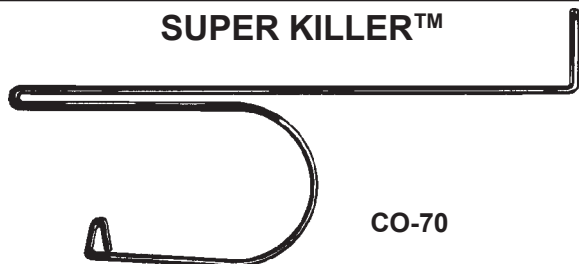

CO-70

The Super Killer™ with its extra length and great strength can be used to open a wide variety of vehicles. By inserting the tool at an angle, it can get under the deepest windows. The strength of the Super Killer™ is such that it can be used to push, pull or lift lock indicators, even those operated by power door locks. The CO-70 can open many new vehicles, especially GM's.

STRETCH DOUBLE "L"

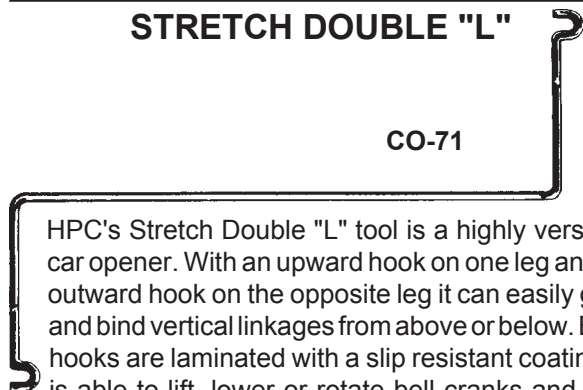

CO-71

HPC's Stretch Double "L" tool is a highly versatile car opener. With an upward hook on one leg and an outward hook on the opposite leg it can easily grab and bind vertical linkages from above or below. Both hooks are laminated with a slip resistant coating. It is able to lift, lower or rotate bell cranks and lazy pawls. It is also able to reach around many shields. The Stretch Double "L" tool works best on doors with thick door panels. It can be used on all General Motors, Ford Lincoln Mercury, Mitsubishi, Mazda, Honda, Hyundai, Chrysler/Plymouth, Toyota, Nissan, BMW, Jaguar and many more.

SHORT DOUBLE "L"

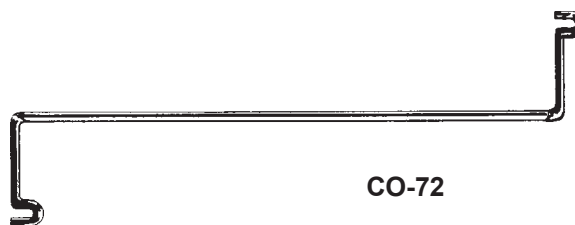

CO-72

HPC's Short Double "L" tool is a highly versatile car opener. With an upward hook on one leg and an outward hook on the opposite leg it can easily grab and bind vertical linkages from above or below. Both hooks are laminated with a slip resistant coating. It is able to lift, lower or rotate bell cranks and lazy pawls. It is also able to reach around many shields. The Short Double "L" tool works best on doors with narrow panels. It can be used on all General Motors, Ford Lincoln Mercury, Mitsubishi, Mazda, Honda, Hyundai, Chrysler/Plymouth, Toyota, Nissan, BMW, Jaguar and many more.

LASSO™



CO-73

The Lasso™ tool is for vehicle entry when the lock button is visible. It is made of high quality "poly-flexo" material with a durable string. The tool allows you to wrap the string around the lock button and lift up to unlock the door.

TRIP TOOL™

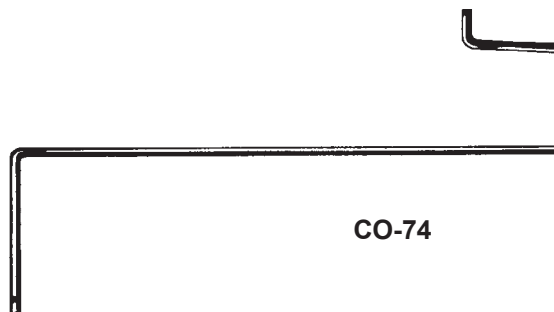

CO-74

The Trip Tool is designed to rotate the bell crank within an inner door panel. It can also be used to lower, raise or rotate bell cranks, lazy pawls or exposed linkages. The Trip Tool easily opens Toyota Previa and Camry. Plus, it can be used on Nissan, Mercury and Chrysler.

AUTO TOOLS



CAR OPENERS

HORIZONTAL CLUTCH™

CO-75

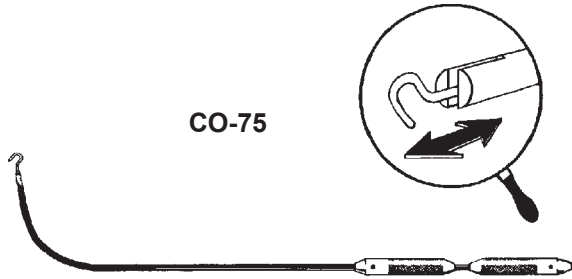

The Horizontal Clutch™ is unlike any others on the market. When the handle of the tool is pulled apart, the hook at the end of the tool is pulled inward, causing the tool to grip or bind the linkage rod. This new type of car entry tool will help to simplify the "in-the-door" method of vehicle entry. The Horizontal Clutch™ is for vehicles with horizontal linkage. (Patent Pending)

VERTICAL CLUTCH™

CO-76

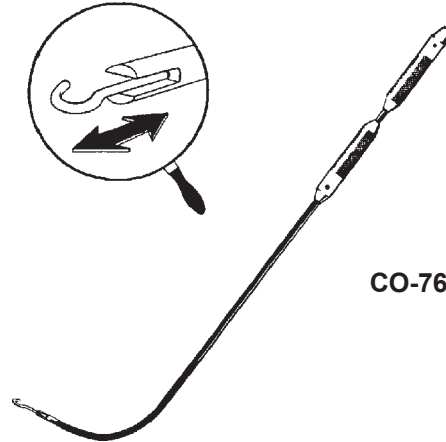

The Vertical Clutch™ is unlike any others on the market. When the handle of the tool is pulled apart, the hook at the end of the tool is pulled inward, causing the tool to grip or bind the linkage rod. This new type of car entry tool will help to simplify the "in-the-door" method of vehicle entry. The Vertical Clutch™ is for vehicles with vertical linkage. (Patent Pending)

AUTO TOOLS

HPC CAR OPENER KITS

HPC's new **Modular Killer Kits** allow you to build your car opener kit from a Starter Kit to an Ultimate Kit or anywhere in between. There are five kits available (Starter Killer Kit, Pro Killer Kit, Deluxe Killer Kit, Classic Killer Kit, and Ultimate Killer Kit), each one adds several tools that are not included in the previous kit.

A STARTER KILLER KIT™

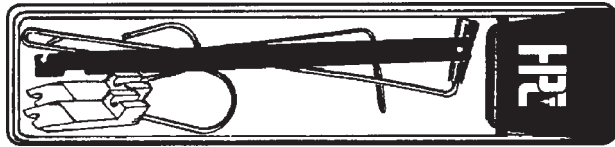

AKK-55

The Starter Killer Kit™ includes the Super Jim™ (CO-11) for vertical rods, Jim Dandy™ (CO-22) for under button, Horizontal Hook (CO-39) for horizontal linkages, the Stretch Killer™ (CO-61) for under and over style openings, and 3/8" auto wedges (AW-38). All these tools complete in a clear view plastic case.

B PRO KILLER KIT™

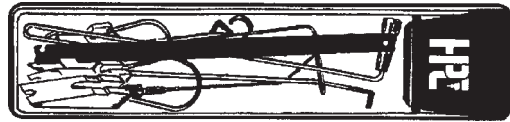

AKK-66

The Pro Killer Kit™ includes all the same tools as the Starter Kit, plus the Safari Joe™ (CO-62) for horizontal offset linkage, the Collapsible Opener (CO-6) for through the car, Mercedes Benz Opener (CO-21) for vacuum locks, Flex-A-Light™ (FAL-15), and 3/4" auto wedges (AW-34). The Pro Killer Kit comes complete in a clear-view plastic case.

C DELUXE KILLER KIT™

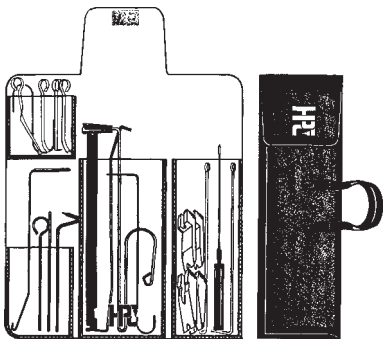

AKK-77

The Deluxe Killer Kit™ includes all the same tools as the Pro Killer Kit, plus the Deluxe Car Opener Set (CO-4) for vented windows, the VW Vent Tool (CO-38), the Chrysler Tool (CO-37), the Jimmy™ (CO-26), the Ford Through Tool (CO-51), and a three fold clear-view large plastic case.

D CLASSIC KILLER KIT™

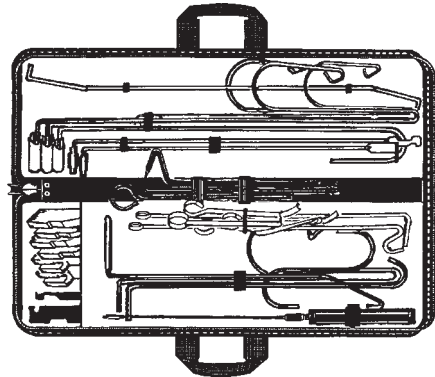

AKK-88

The Classic Killer Kit™ includes all the same tools as the Deluxe Killer Kit, plus all the HPC classics including the Ultra Jim™ (CO-55), the Flexible Peg Leg™ (CO-56), the J Flex™ (CO-57), the original Slim Jim™ (CO-10), the Super Killer™ (CO-70), the Caddy Killer™ (CO-60), and the Beretta Opener (CO-59). The Classic Killer Kit comes complete in a deluxe highly durable custom made carrying case.

E ULTIMATE KILLER KIT™

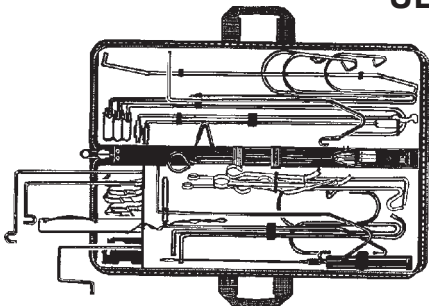

AKK-99

The Ultimate Killer Kit includes all the same tools as the Classic Killer Kit, plus the Over Hook™ (CO-68), the Reverse Over Hook™ (CO-67), the Stretch Double "L" (CO-71), the Short Double "L" (CO-72), the Lasso™ (CO-73), the Trip Tool (CO-74), and the Novice Pick Set (PIP-13). The Ultimate Killer Kit comes complete in a deluxe highly durable custom-made carrying case.

AUTO TOOLS



ACCESSORY PACKS FOR MODULAR KILLER KITS

(FOR UPGRADING KITS ON PREVIOUS PAGE)

The accessory packs listed at the right will upgrade the Modular Killer Kits shown on previous page to the next kit up. For example: if you have a AKK-55 Starter kit and you order a AP-1 accessory pack you will now have a AKK-66 Pro Killer Kit. Each pack contains the tools that are needed to upgrade to the next kit.

No.	Description
AP-1	Turns AKK-55 into AKK-66
AP-2	Turns AKK-66 into AKK-77
AP-3	Turns AKK-77 into AKK-88
AP-4	Turns AKK-88 into AKK-99

UNIVERSAL KILLER KIT™

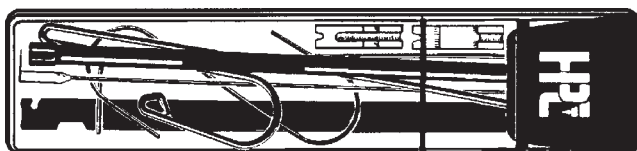

The Universal Killer Kits™ come complete with a black plastic carrying case featuring a clear-view front and fully illustrated instructions and the following tools: AW-38, CO-10, CO-11, CO-22, CO-21, CO-39, CO-40, CO-56, CO-60. The AKK-E10 also comes with the FAL-15 light.

AKK-E10 (Pictured)

AKK-E9 (Same as AKK-E10 excluding FAL-15)

MISCELLANEOUS AUTO TOOLS

A-1



A1-GP1 Plug Puller for G.M.

Pull most G.M. trunk & deck plugs in seconds. Since the G-Pull never touches the auto body, there is no fear of scratching the paint or bending the body. Can also be used for some foreign autos and removable core padlocks, desk locks, etc.



A1-6 G.M. Lock Decoder

Works when others fail. This quality tool makes everyone a professional. Decode all years of G.M. sidebar without complete disassembly.

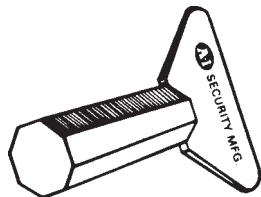

A1-8 Bezel Nut Wrench

Removes bezels found in G.M. glove compartment locks.

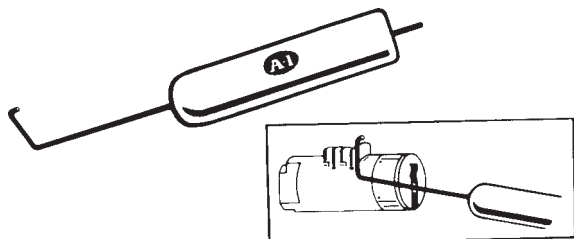

A1-5 G.M. Plug Remover/Poke Tool

A combination glove compartment plug remover and poke tool for ignition locks. To remove glove compartment plug, insert hook between the retainer and the No. 1 wafer. Hook over retainer slide and pull down and out. Works in locked or unlocked position.